

## 8.7 Working Head Indexing Device

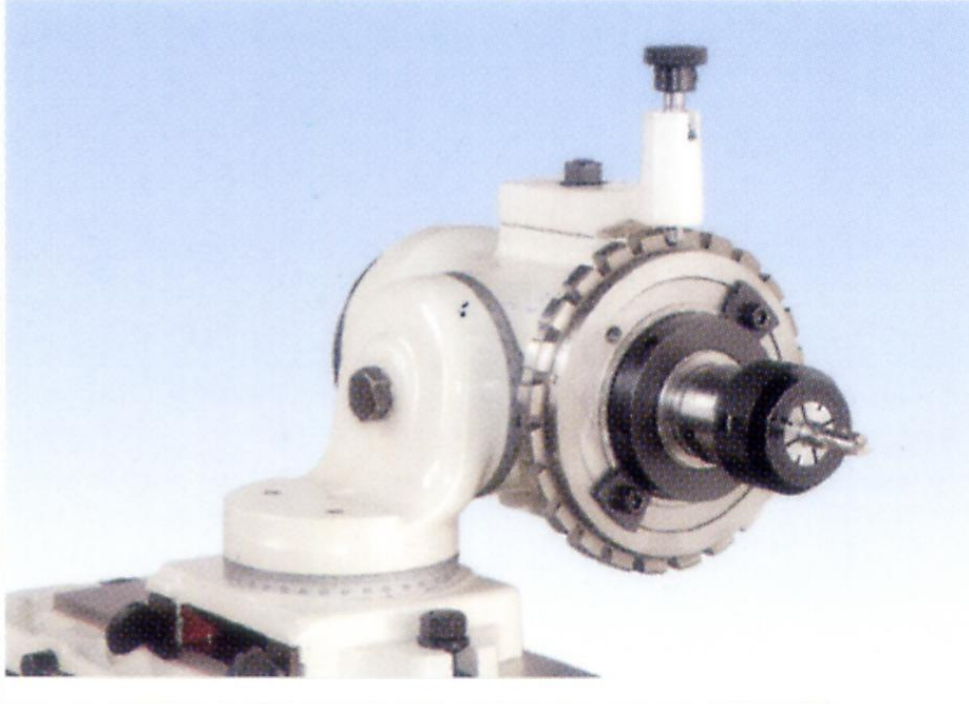

### 1. Introduction

This device universal work to do in the head, can easily quickly and accurately set out the grinding tool to replace the blade angle of the aliquot guide rod, standard specifications for the 24 divisions.

General Specifications: 24 parts

Special specifications: 12T, 14T, 16T, 18T, 20T, 21T, 22T, 32T, 44T, 48T, 36T, 40T, 60T, 72T, 4T, 26T, 28T, 30T.

# Working Head Indexing Device Drawing

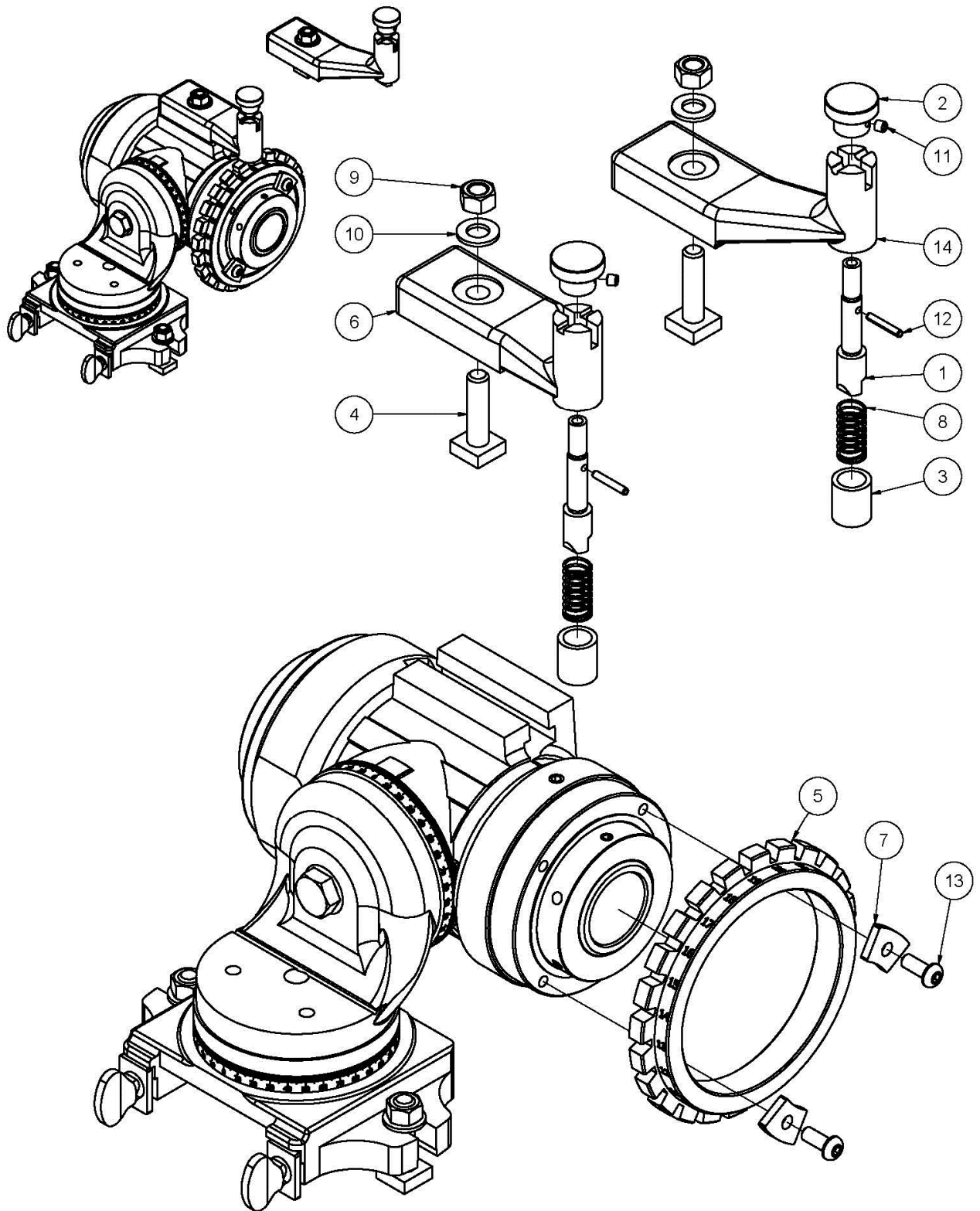

## Working Head Indexing Device List

項目	品號	品名	規格	數量
1	M170050**	Plunge		2
2	M170010**	Plunge head		2
3	M170020**	Bushing		2
4	M450080**	T-bolt		2
5	M17006***	Indexing plate		1
6	M170040**	Jumper Block (Left)		1
7	M170070**	Fixed block		2
8	M170080**	Spring		2
9	GF030360	Hex nut	M12	2
10	GE011644	Washer	12(Black)	2
11	GF010230	Hex screws	M6*6	2
12	GC030357	Spring pin	4*25	2
13	GF014915	Hex button head screws	M8*20	2
14	M170030**	Jumper Block (Right)		1