

PANEL-1

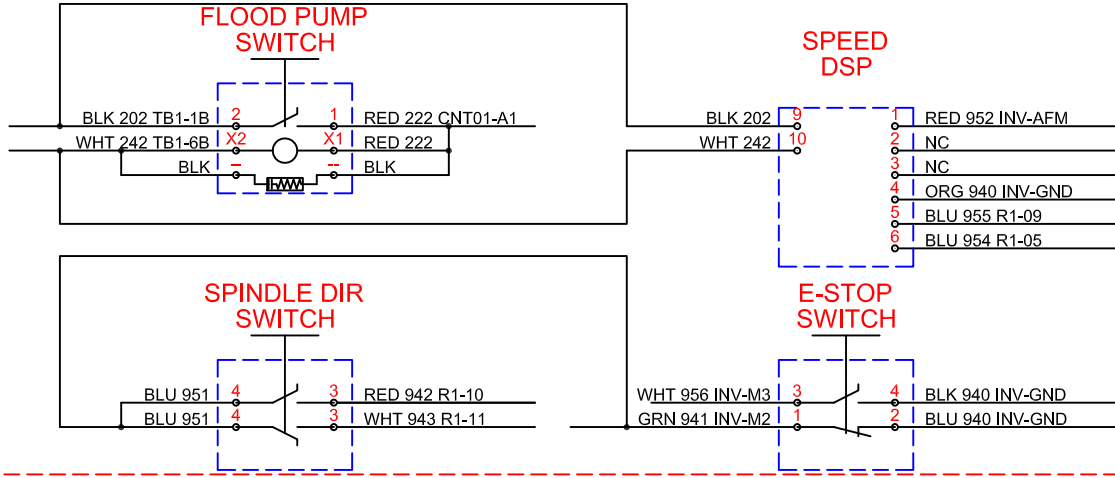

PANEL-2

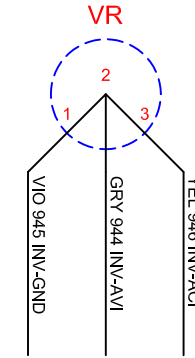
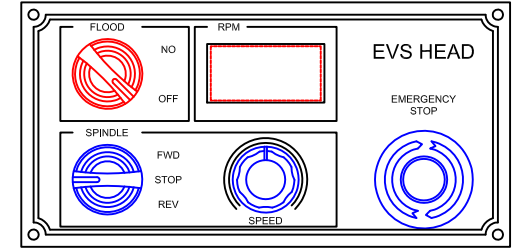

CABINET

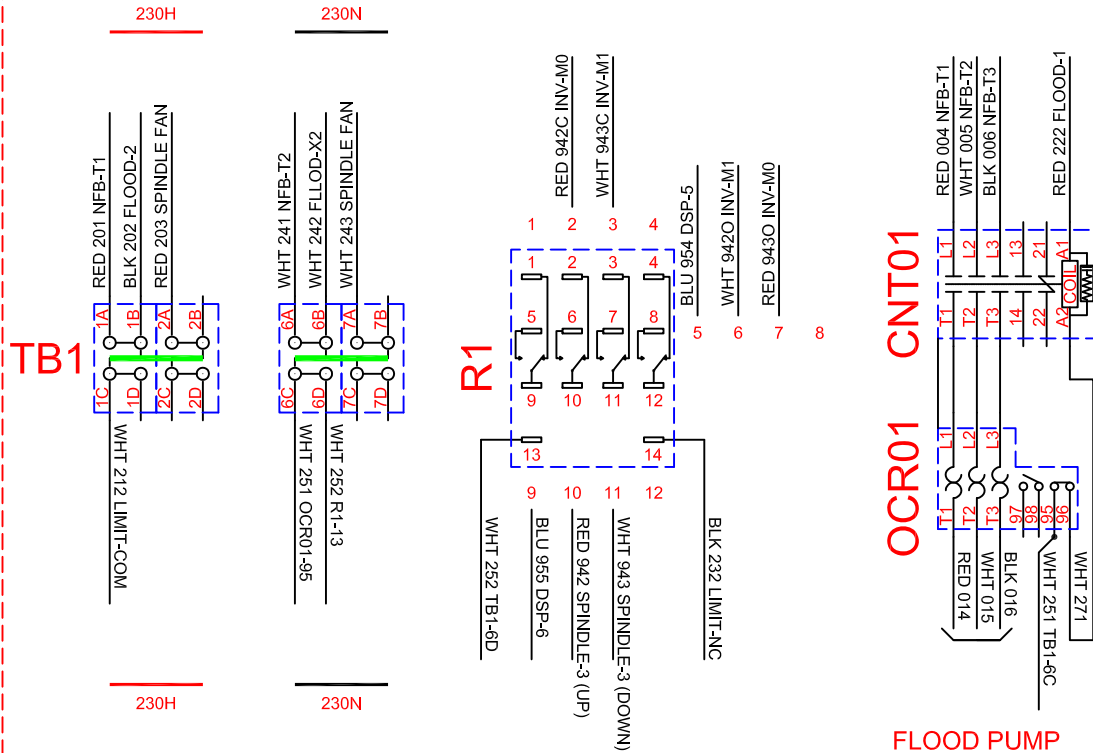

INVERTER

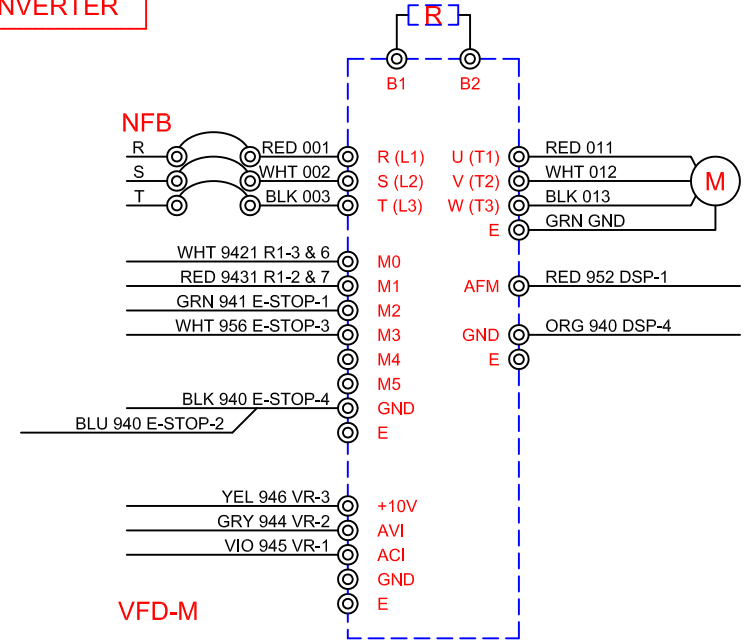

PARAMETER	DESCRIPTION	DATA
0	FREQ SOURCE	1
1	COMMAND SOURCE	2
3	MAX OUTPUT FREQ	134.33
10	ACCEL TIME 1	2.0
11	DECEL TIME 1	3.0
39	MULTI INPUT 2	4
40	MULTI INPUT 3	21